

Balancing Machine for Crankshafts

KHK-ZM

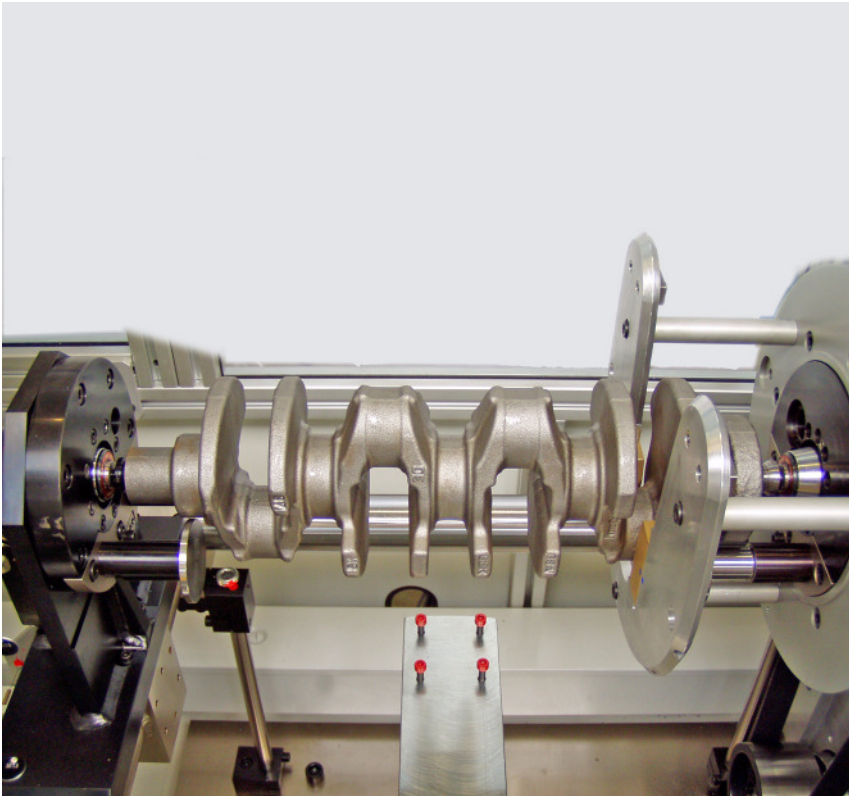

Advantages

- For centered unmachined crankshafts and finished crankshafts.
- Simple retooling to different crankshaft lengths.
- Suited for symmetrical and unsymmetrical crankshafts.

Applications

- Determination of the unbalance and machining offset values of centered unmachined crankshafts.
- The offset values are printed out or linked directly to the center unit.
- Balancing of repair crankshafts.
- Machining of centered unmachined crankshafts to finished crankshafts.
- Application with engine suppliers in series production.

Description

- Soft-bearing horizontal balancing machine for unbalance measurement in two planes.
- Measuring system in frame mode with longitudinal adjustment for retooling to different crankshaft lengths.
- Selectable support
 - between pneumatically operated centres
 - on ground carbide rollers
- Drive via hook drive. The driving jaws are exchangeable for adaption to the pin width of unmachined part or machined crank pins.
- Compensation weights are used for balancing of unsymmetrical shafts.



General view

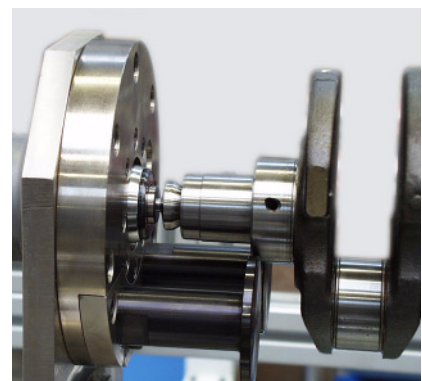

Centering and load support

All information without obligation, subject to change without notice

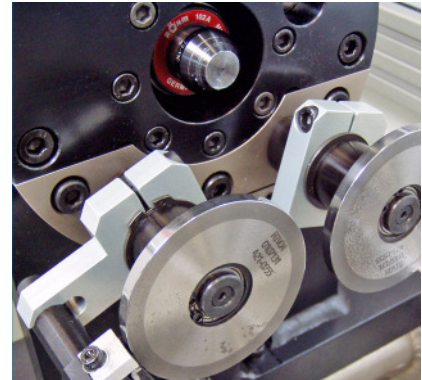
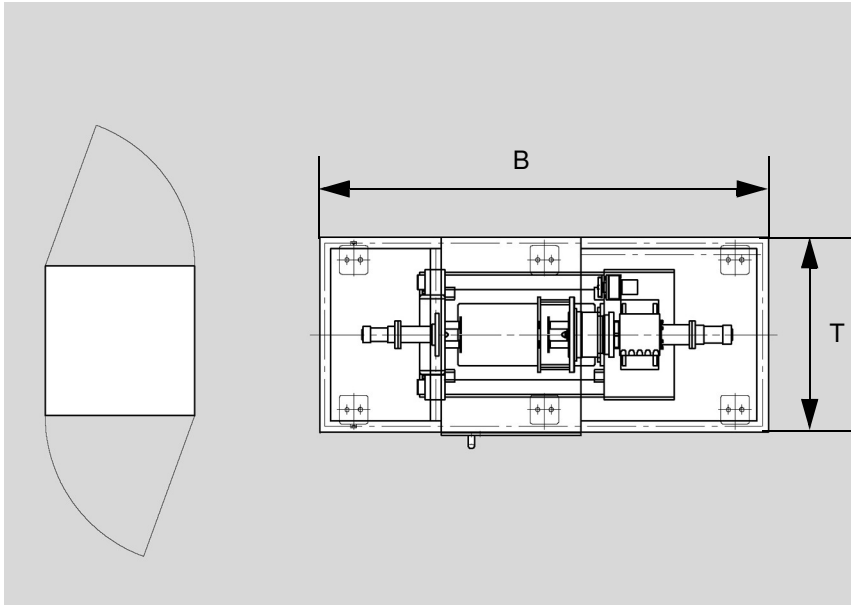

Ground carbide roller for measurement of finished parts

Technical data

		KHK21-ZM	KHK12-ZM
Rotor:			
Weight	kg	6 - 30	15 - 120
Total length	mm	300 - 700	300 - 1100
Main bearing diameter	mm	30 - 70	30 - 80
Counterweight radius	mm	60 - 85	60 - 170
Machine:			
Width x depth x height	mm	1800 x 800 x 1400	2100 x 1250 x 1550
Balancing speed	min ⁻¹	200 - 650	200 - 650
Repeatability ¹⁾	gcm	2 - 3	3 - 5

¹⁾ depending on workpiece

Options

- Ground carbide rollers
- Compensation weights for unsymmetrical crankshafts
- Correction value report
- Master part with calibration weights
- Drilling unit for manual correction of n.o.k. crankshafts
- Feedback to central drilling unit

Scope of supply

- Vibrating frame with two transducers
- Bearing support with drive-spindle, hollow-shaft-type, and centring tool
- Hook drive
- Axial guidance
- Control cabinet
- Measuring system
- Protective equipment Class B as per ISO 7475
- Pneumatic unit